

UV Product Brief

This product brief provides an overview of the Ultraviolet offering, including product features and applications.

Contents

1. UV Overview	2-4
2. Ultraviolet A (UVA) Solutions . .	5
3. Ultraviolet C (UVC) Solutions .	6
4. Ultraviolet A Product Line	7
5. Ultraviolet C Product Line	8
5. Specifications and Reliability . .	9



- **Optoelectronic** core focus
- **Comprehensive** package selection offering robust reliability and longevity
- **Application** and engineering support available, including optical simulation
- **Custom** solutions and special binning

UV Overview

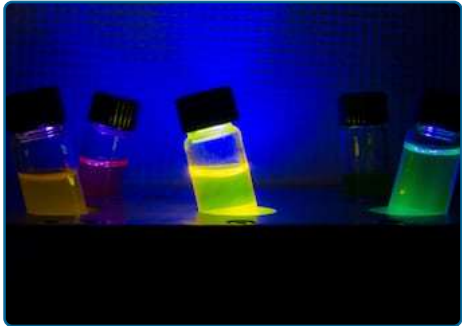

Product Features

- Exceptionally long lifetime
- Compact surface-mount packages
- Film gold-plated metallized substrate
- Low thermal resistance (4~6°C/W)
- RoHS-compliant and halogen-free
- Moisture sensitivity level 4 in accordance with J STD-020
- ESD 8KV
- Quartz or Silicone lens
- Ceramic substrate with Aluminum Oxide or Aluminum Nitride

Applications

- Industrial and Cosmetic Curing
- Resin curing (3D Printing)
- Scientific and Biological Tools
- Sterilization, Disinfection, Purification
- Horticulture
- Medical Tools
- Phototherapy / Skin Therapy
- Counterfeit detection tools
- Blacklight / Fluorescence light

IN-C33CTNU



IN-K2PUV



IN-C40PUCTKU1

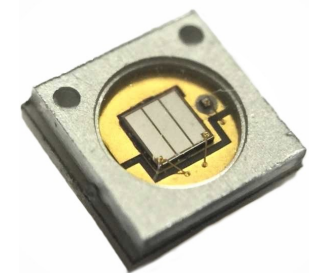

UV Product Overview

UV Type	Wavelength (nm)	Radiant Flux (mW)	Viewing Angle
UVA	365 - 420	400 - 6000	30, 60, 120
UVC	265-285	2.5 - 20	30, 60, 120, 130

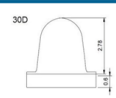
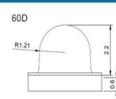
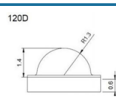
Viewing Angle Options		
A	30°	
B	60°	
C	120°	

Lens Options	
390 - 420nm	Silicone Lens
360 - 390nm	Silicone or Quartz Lens
260 - 360nm	Quartz Lens

UV Type	Rapid Degradation (Materials such as Plastic and Rubber)	Common Applications
UVA	Not Typical	Curing, Medical, and Sensing
UVC	Yes	Germicidal, Disinfection, and Industrial

Medical Applications



Sterilization

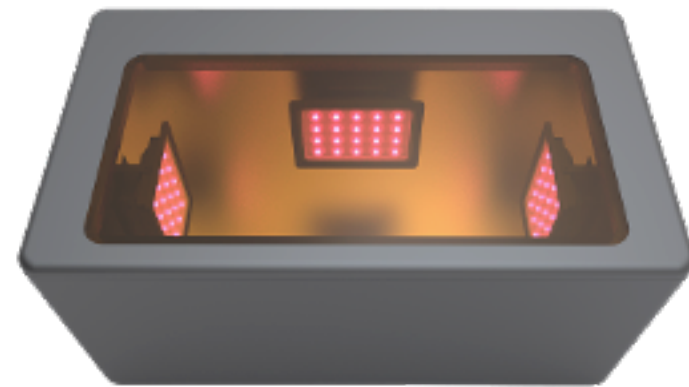
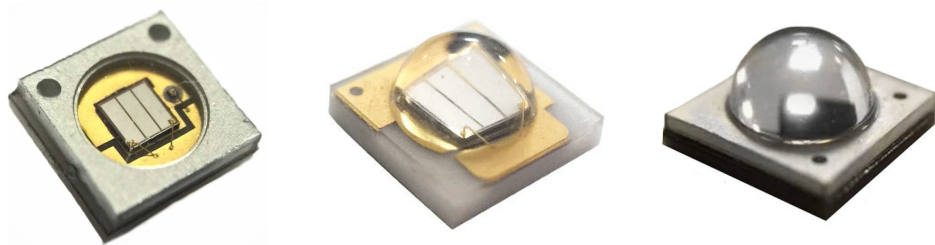

- Air Purification
- Wastewater treatment
- Surface Disinfection

- Water Purification

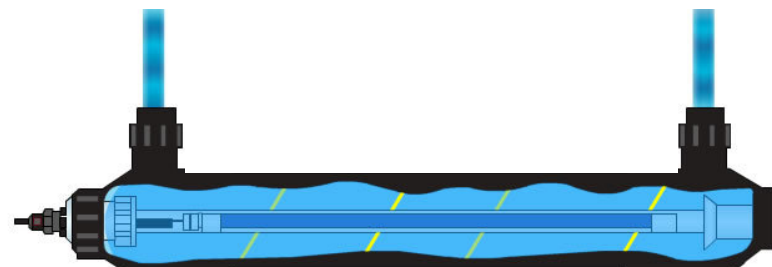

UVA Solutions

Relative Spectral Power Distribution

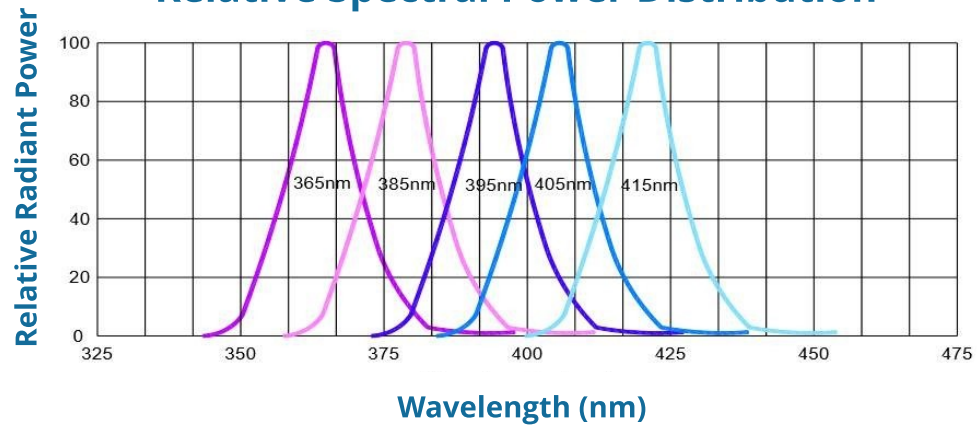

Applications

- UVA: 360-420nm
- Curing
- Counterfeit Detection
- 3D Printing
- Phototherapy
- Assembly Line Inspection
- Food Processing



UVC Solutions

Relative Spectral Power Distribution

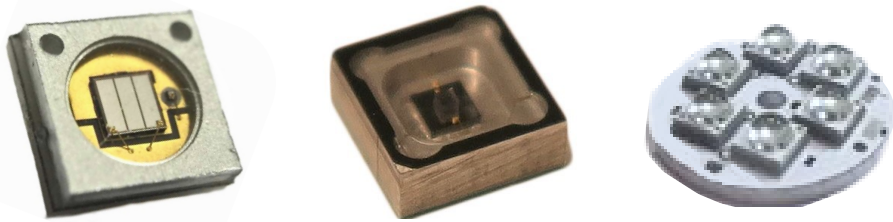
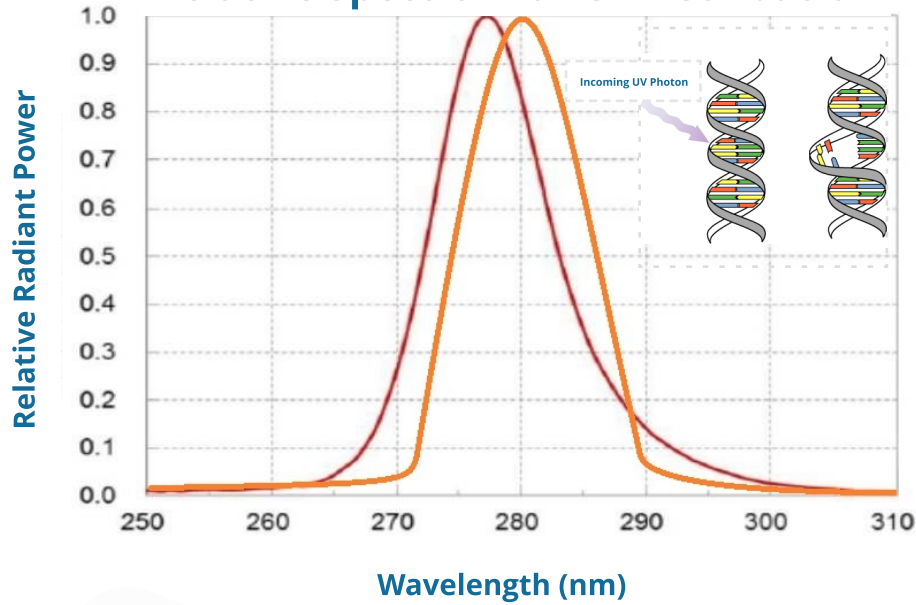

Applications

- UVC: 265-285 nm
- Water Disinfection
- Industrial Packaging
- Food Processing
- Germicidal
- Horticulture
- Assembly Line Sterilization

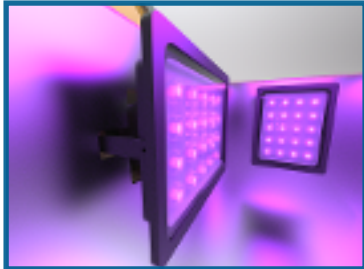

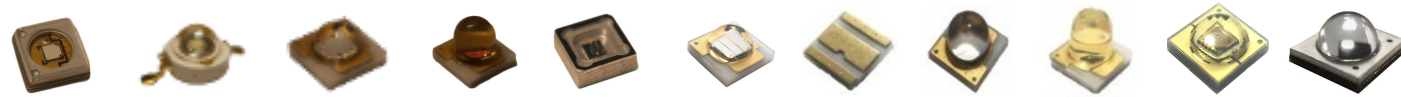

UVA Product Line

Product	Pulse Current	Max DC	Test Current	Vf Typ.	Wavelength	Radiant Flux	Radiant Flux	Radiant Flux	Dimensions	Tj	Rth
	Max (mA)	(mA)	(mA)	(V)	(nm)	(mW) @500mA	(mW) @700mA	(mW) @1A	(mm)	Deg	°C/W
IN-3531SCUV-U70	1000	800	500	3.4	410-420	800	1000		3.45 x 3.45	150	8
IN-3531ACUV-U70	1500	1000	500	3.6	410-420	800		1000	3.45 x 3.45	150	4.4
IN-C33ATNU7LU	1500	1000	500	3.6	410-420	850			3.50 x 3.50	90	5
IN-3531SCUV-U60	1000	800	500	3.4	400-410	800	1000		3.45 x 3.45	150	8
IN-3531ACUV-U60	1500	1000	500	3.6	400-410	800		1000	3.45 x 3.45	150	4.4
IN-C33ATNU6LU	1500	1000	500	3.6	400-410	850			3.50 x 3.50	90	5
IN-C33xTNU5	1500	1000	500	3.6	390-400	1200	1550		3.50 x 3.50	150	4.5
IN-C39xTOU5	1800	1200	1000	3.8	390-400			2000	3.90 x 3.90	85	4.5
IN-C33ATNU5LU	1500	1000	500	3.6	390-400	850			3.50 x 3.50	90	5
IN-C33xTNU4	1500	1000	500	3.6	380-390	1200	1550		3.50 x 3.50	150	4.5
IN-C39xTOU4	1800	1200	1000	3.8	380-390			2000	3.90 x 3.90	85	4.5
IN-C33ATNU4LU	1500	1000	500	3.6	380-390	850			3.50 x 3.50	90	5
IN-C33xTNU2	1500	1000	500	3.6	365-370	800	1000		3.50 x 3.50	150	4.5
IN-C39xTOU2	1800	1200	1000	3.8	365-370			1800	3.90 x 3.90	85	4.5
IN-C33ATNU2LU	1500	1000	500	3.6	365-370	540			3.50 x 3.50	90	5
IN-C68QA(X)TMU(X)	1200	1000	500	3.6	365-400		3000-6000		6.80 x 6.80	85	2



UVC Product Line

Product	Viewing Angle	Material	Max DC	Vf Typ.	Wavelength	Radiant Flux	Radiant Flux	Dimensions	Tj	Rth
			(mA)	(V)	(nm)	(mW)	(mW) @500mA	(mm)	Deg	°C/W
IN-C35PUDTDU1	130	Ceramic	20	6.9	265-285	2.5	60	3.5 x 3.5 x 1.43	60	55
IN-C40PU(X)TK	30, 60, 90	Ceramic	100	7	270-285	10	10	3.9 x 3.9 x (X)	65	15



Packaging Material

- **Advanced Gold Plating Film Process**
 - Improved thermal conductivity
 - Greater reliability
 - Improved light reflectance *Compared to conventional plating
- **Quartz Lens**
 - Low UV absorbance, high transmittance *Compared to competitive K9 lens
- **Aluminum Nitride Substrate**
 - Higher thermal conductivity *Compared to Aluminum Oxide Substrate
- **Thermal Expansion Coefficient Matching Material**
 - Less induced internal stress

Lifetime and Reliability

Features	UV LED	Mercury Lamp
Lifetime	25k Hours	10k Hours
Safety	No Heavy Metals	Hazardous
Security	Low-Voltage / simple drive circuit	Shock Sensitive
Energy	Low Power Consumption	High Power Consumption

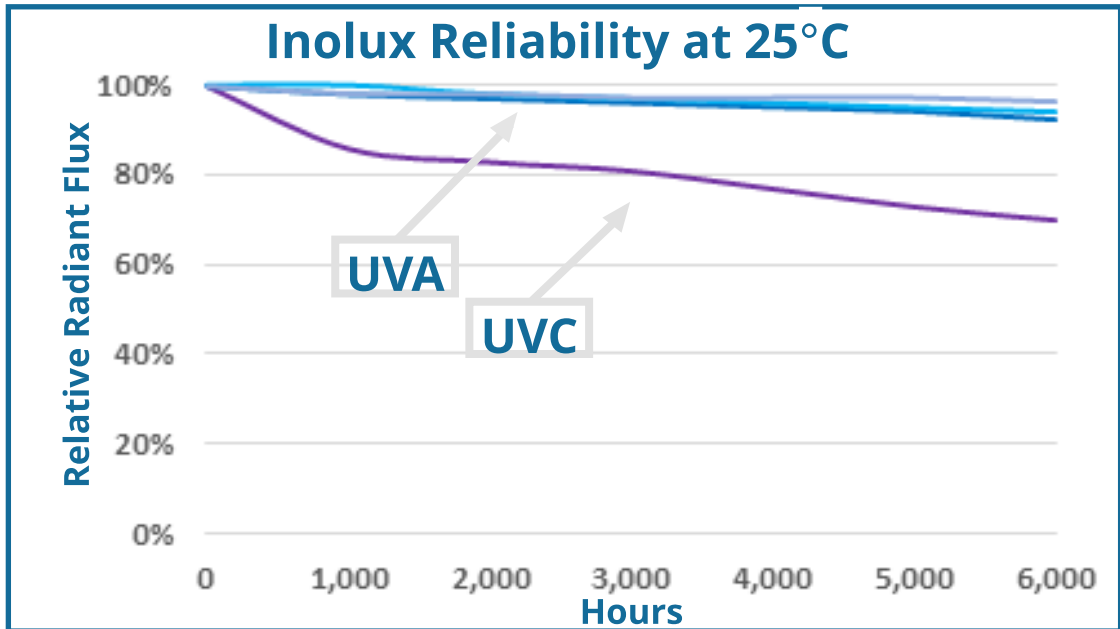

Key Technologies

- **Eutectic Process**
 - 5 times more heat transfer capacity than silver glue
- **High Driving Current**
 - Up to 1.8A
- **Low thermal resistance**
 - 4 to 6 deg/W

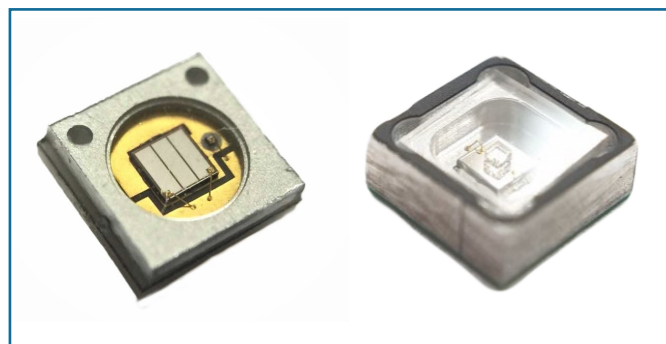

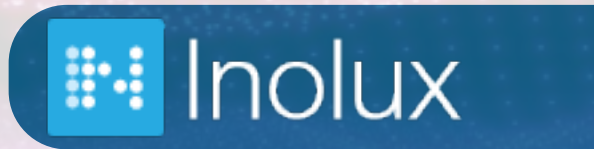

Contact Us



Santa Clara, California
USA

Phone: (408) 884 3871

Email: Sales@Inolux-Corp.Com

For more information on the UV line including features,
applications, and specifications, or to view additional
parts in this product family, visit:

Inolux-Corp.Com